



3U VPX enables greater performance and connectivity in small form factors

By Michael Slonosky and Jing Kwok

With the rising popularity of small form factors in the face of growing military SWaP concerns, the 3U form factor, particularly CompactPCI, has made strong market inroads. However, VPX (VITA 46) is emerging as a more viable contender than 3U CompactPCI, providing increased speeds, more bandwidth, and compatibility via high-speed serial fabrics in mission computers and other critical technology.

Editor's Note: In the race between MicroTCA and rugged VPX, BAE Systems showed off its new WIN-T proof-of-concept box at MILCOM, featuring a JC4ISR Radio Architecture implemented on conduction-cooled AdvancedMC cards in a PICMG-inspired MicroTCA chassis. However, as you're about to read, longtime conduction-cooled 6U VME LRU supplier Curtiss-Wright Controls Embedded Computing is placing much of its confidence in VITA's 3U VPX standard for future deployments. This edition, we're gearing up for this standards clash. And, in our April edition, we'll give rugged MicroTCA its fair share of detailed coverage as well. We believe that the three rival rugged standards of 3U VPX, 3U CompactPCI, and MicroTCA will all prove themselves viable contenders in future critical systems.

As demands for reduced Size, Weight and Power (SWaP) have risen for embedded military and aerospace systems, the size and modularity of the 3U form factor in particular has made it the card size of choice for a large number of newer technology platforms such as UAVs.

CompactPCI legacy compatibility ensured with 3U VPX

3U VPX was designed, in part, to ensure compatibility and continuity with the legacy CompactPCI ecosystem. Because the new standard supports CompactPCI's chassis pitch of 0.8", 3U VPX cards can be used for upgrades or replacements in existing CompactPCI systems by simply replacing the backplane without changing the chassis. In addition, the VPX VITA 46.9 standard provides a definition for mapping PMC and XMC differential I/O, enabling the use of legacy and next-generation mezzanine modules. 3U VPX also preserves the PICMG 2.0 Rev 3 air-cooled envelope and includes support for VITA 30.1 specified conduction cooling.

Accordingly, although CompactPCI has become an increasingly popular 3U choice in military/aerospace embedded system design, military system designers continue to demand higher speeds, more bandwidth, and serial fabric connectivity than it can provide. These demands are outstripping the capabilities of CompactPCI, forcing military system designers to turn to proprietary solutions in order to find all of these features in a single-board architecture.

Enter the new 3U VPX (VITA 46) and VPX-REDI (VITA 48) open standards, which offer several advantages over 3U CompactPCI. 3U VPX provides a standards-based COTS remedy that can support today's military applications and provide the faster speeds, higher bandwidth, and improved connectivity via high-

speed serial fabrics that 3U CompactPCI cannot. This can be clearly seen in a mission computer case study such as the one presented herein.

3U VPX/VPX-REDI satisfy the need for speed, bandwidth

One thing for designers to consider when choosing between VPX and CompactPCI is that the bandwidth of CompactPCI's PCI bus does not support high-speed applications such as signal processing and radar. Designers of these higher-bandwidth applications want to take advantage of the faster speeds made possible with serial switched fabrics, such as PCI Express (PCIe) and Serial RapidIO, shown in Table 1. The maximum transfer rate in a six-slot 32-bit CompactPCI bus is 33 MHz or 133 MBps, not nearly fast enough for

Comparison of Small Form Factor Bus Architectures

	CompactPCI	CompactPCI Express	3U VPX	VME
Bandwidth	32/33 = 133 MBps	24 lanes PCIe = 12 GBps	8 lanes PCIe/Serial RapidIO = 4/5 GBps	A24/D16 = 20 MBps
User I/O pins	75 as "system" 105 as "peripheral"	30	72P2 + 32diffP1 + 4P1 = 108	0
LRM	No	No	Yes	No
Conduction cooling	Yes	No	Yes	Yes
Liquid cooling	No	No	Yes	No
Shock and vibration performance	Good	Good	Excellent	Good

Table 1

the intercard bandwidth requirements in high-performance systems requiring higher than 1.5 Gbps. In addition, new multicore platform processors come with embedded, high-speed fabric interconnects that 3U CompactPCI simply can't take advantage of to their fullest extent.

The 3U VPX and VPX-REDI standards were created with these limitations in mind. Both standards deliver an order of magnitude higher bandwidth than older small form factors, with VPX and VPX-REDI delivering 4 to 5 Gbps with the defined eight fabric lanes of either PCIe or Serial RapidIO. For high-speed, bandwidth-intensive applications, VPX's MultiGig RT2 connector supports signaling up to 6.25 Gbps on each differential pair and more with advanced SERDES technologies. 3U VPX can thus take complete advantage of the high-speed interconnects provided with new multicore platform processors. For example, the P.A. Semi 1682 has 24 flexible SERDES engines, and the Freescale 8641 has dual eight-lane PCIe or SRIO ports.

Building an aircraft mission computer with 3U VPX

One of the benefits of VPX is its compatibility with high-speed serial fabrics for improved connectivity. For inter-processor communications in a typical 3U CompactPCI system, communications

occur over the CompactPCI bus. As the bus is only 32 bits wide, has a maximum clock rate of 33 MHz in a six-slot system, and is shared among all cards present on the bus, high-performance data transfer between cards is limited to 133 MBps. If necessary, designs could make use of high-speed fabrics such as StarFabric to interconnect processors directly and bypass the CompactPCI bus to effectively increase the system bandwidth by using this sideband link. But the added cost and power that results means that the mezzanine sites are not available for other functions. The effect is to limit 3U CompactPCI system functionality.

VPX, on the other hand, was designed to allow system designers to interconnect cards with high-speed serial fabric directly on the backplane. Today, newer multicore platform processors can include a multitude of high-speed serial fabric interfaces on-chip. When these new processors are combined with VPX's ability to handle high-speed fabrics, it is possible to increase system performance, reduce power consumption, and reduce board count.

Increased system performance, combined with reduced power consumption and board count becomes highly relevant in critical systems such as mission computers aboard smaller aircraft. In an

airborne platform, the mission computer's functions can include signal processing, subsystem exception and status management, mission profile storage, pilot work offload, moving maps, and information control. These systems may experience severe space and weight constraints in very small aircraft, such as a small, two-seater, turboprop aircraft used in military training. For example, a lightweight, compact, conduction-cooled processor and graphics display controller subsystem that functions as a typical mission computer can be built today out of commercial components, such as 3U CompactPCI SBCs.

Figure 1 shows a mission computer design consisting of six cards. A pair of SBCs is used for the signal processing function utilizing a Star Fabric link for high-speed interprocessor communications between the pair. A second pair of SBCs, each with a graphics mezzanine card, is used to perform the graphics functions. The fifth SBC provides a 1553 PMC mezzanine card to handle the 1553 protocol. The sixth slot CompactPCI carrier card holds an analog board. This analog board may be an ARINC 429 mezzanine card or another type of analog board with A/D and/or 28 V external signaling.

VPX technology, along with the new platform processors with integrated serial fabrics, allow the system designer to combine the signal processing and graphics functions onto only two processor cards. Figure 2 shows an equivalent mission computer using a 3U VPX system. This mission computer is implemented with only two processor cards and two carrier cards, where each processor card hosts a graphics mezzanine. An example of a processor card is Curtiss-Wright Controls Embedded Computing 1.5 GHz P.A. Semi PWRficient PA6T-1682M-based VPX3-125 SBC (Figure 3).

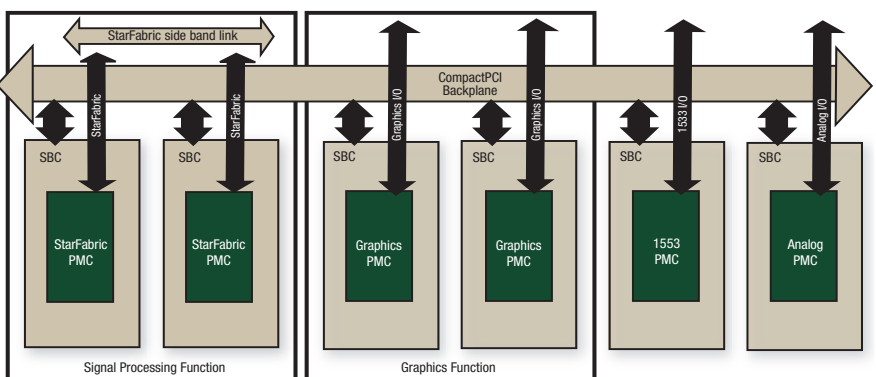

Figure 1

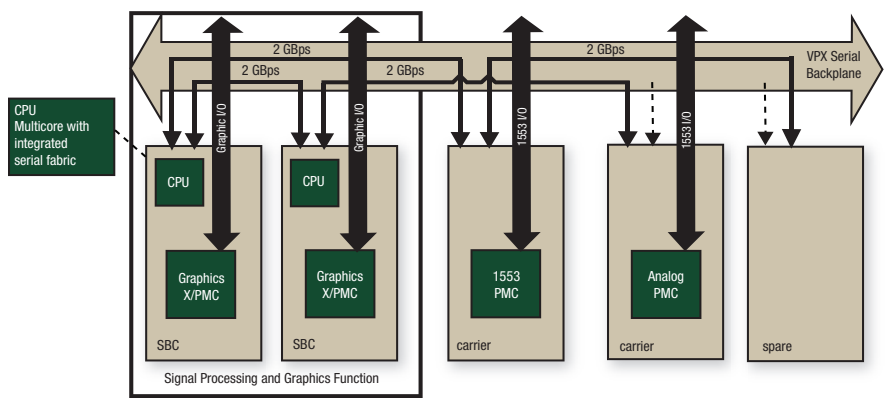

Figure 2



Figure 3

3U VPX allows the board designer to make full use of the features of this next generation of platform CPU chips in the most efficient manner. The high-speed serial interfaces of these chips can be directly connected to the VPX backplane without the need for serial-to-parallel bridge conversion chips, as would be

needed with CompactPCI. The two serial interfaces can operate at an aggregate bandwidth of 4 GBps using the PCIe protocol, compared to the shared 133 MBps of CompactPCI. The serial interfaces can also provide the interprocessor communication function that was provided by the sideband StarFabric link shown in the CompactPCI example. I/O bandwidth on the 3U VPX boards is also greatly enhanced: Each pin on VPX can achieve 6.25 Gbps, enabling next-generation I/O such as SATA, 10 GbE, and high-resolution graphics attachments.

The third and fourth slots contain carrier cards, such as the Curtiss-Wright VPX3-215 ExpressReach, a 3U VPX I/O expansion carrier card that provides XMC and PMC hosting capabilities. In this example, the carrier card in slot three holds a 1553 mezzanine card. Since one of the cores on the platform CPU in the first slot can easily handle the 1553 protocol processing, a separate SBC is not required.

The carrier card in the fourth slot case holds the analog mezzanine card as in the CompactPCI system, and again since one of the cores on the platform CPU in the second slot can easily handle the analog processing.

VPX beats out 3U CompactPCI as military form factor of choice

In the future, the trend will be toward the increased use of 3U technology as well as continued expansion of functionality and performance. In the past, systems based on 3U CompactPCI and now 3U VPX have been used primarily in mission control computers. But with the advent in the next several years of quad and octal core processors from various CPU chip manufacturers, the 3U VPX form factor will be able to support higher-performance systems (DSP, signals intelligence) with less space, weight, and power and for a lower cost. **CS**



Michael Slonosky is product marketing manager for PowerPC SBCs in the Modular Solutions Division at Curtiss-Wright Controls Embedded

Computing (CWCEC). He has been with CWCEC for 5 years after spending more than 20 years in the telecom industry. Mike is a graduate of the University of Manitoba. Michael can be reached at michael.slonosky@curtisswright.com



Jing Kwok is chief engineer in the Modular Solutions Division at Curtiss-Wright Controls Embedded Computing. He has been involved

with VMEbus standards work for the past 15 years. He is chairman of the VITA 46 Working Group. He is also an editor of one of the VITA 46 "dot" specifications now in working group ballot and was one of the chapter editors for the VME 64 specification. Jing is a graduate of the British Columbia Institute of Technology. Jing can be reached at jing.kwok@curtisswright.com

**Curtiss-Wright Controls
Embedded Computing**
703-779-7800
www.cwcembedded.com